

PLAN

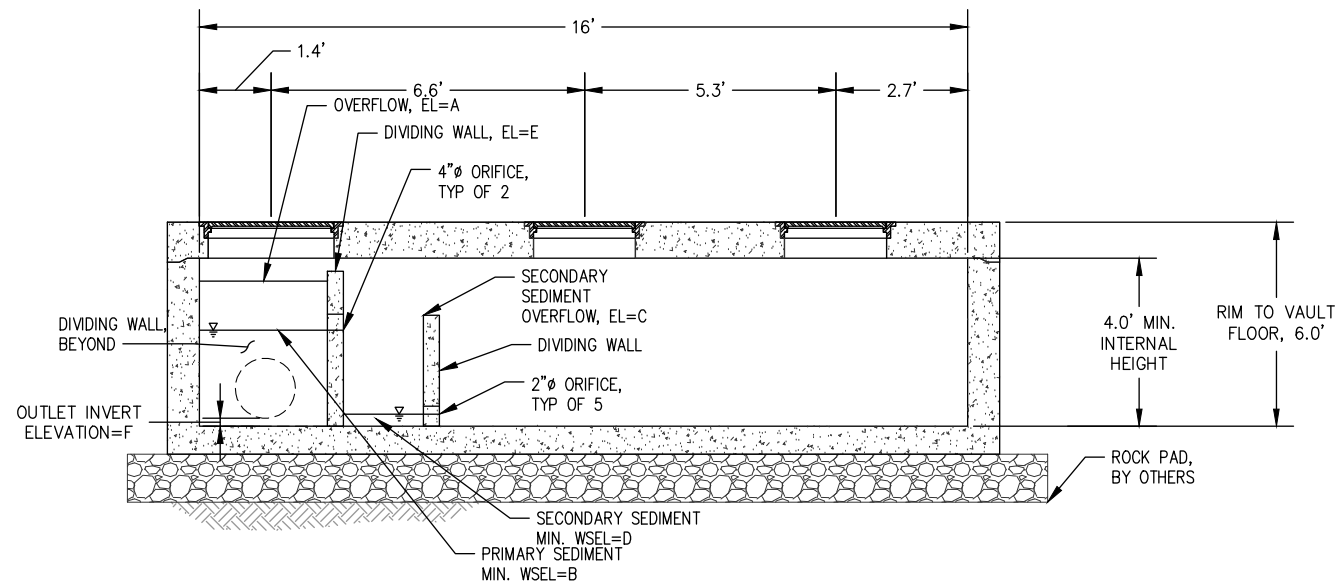

SECTION A

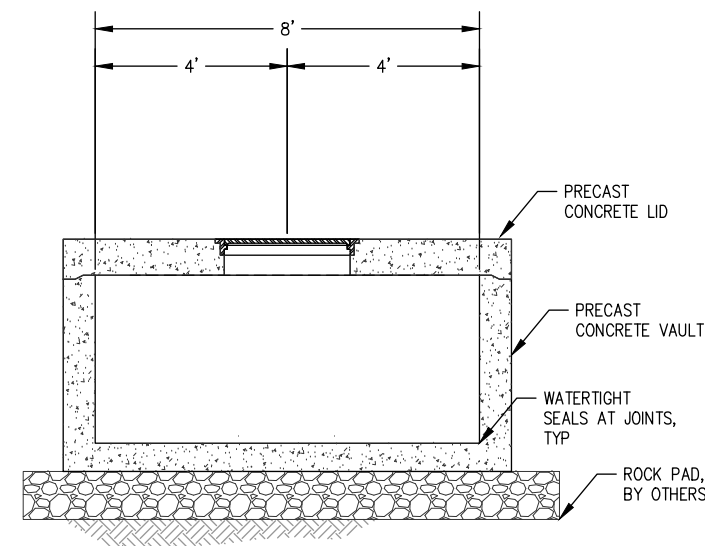

SECTION B

TREATMENT VAULT

- ELEVATIONS:
 A = 43" ABOVE VAULT FLOOR
 B = 24" ABOVE VAULT FLOOR
 C = 28" ABOVE VAULT FLOOR
 D = 3" ABOVE VAULT FLOOR
 E = 45" ABOVE VAULT FLOOR
 F = 2" ABOVE VAULT FLOOR
- ALL DIVIDING WALLS SHALL BE CONCRETE, MINIMUM 4" THICKNESS.
- SEE WATER SURFACE ELEVATIONS (WSEL) FOR LOCATING ORIFICES.

81944	1 OF 1	CONT/CONS: 071579	M. ID: 101531.01	PHASE: BID	TOWNSHIP: 20N	DATE-HR Z: WA-83-SF	PARCEL: 5000350150	RANGE: 3E	SECTION: 01SE	PORT OF TACOMA BM#	DRAWING SCALE: AS SHOWN	APPROVED:	CB	05/23/2022	CHECKED BY	DATE
													NW	06/02/2022	PROJ. ENGR	DATE
<p>Parcel 15 (Portac) Cleanup</p> <p>Stormwater Vaults</p>																
<p>2407 North 31st Street, Suite 100 Tacoma, WA 98401 (253) 396-0150 Fax (253) 396-0152</p>													APPR: DATE:	BY: REVISION:	MARK: REVISION:	